

NAIS

**ONE OF THE SMALLEST
SNAP-ACTION SWITCH
IN THE WORLD**

FU (AV4) SWITCHES

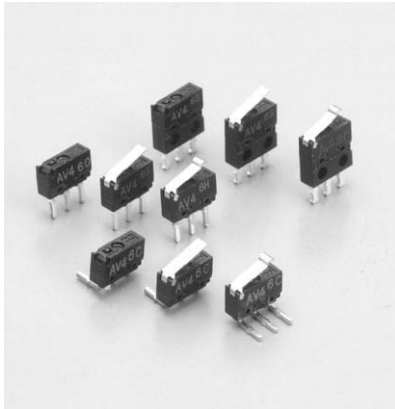

FEATURES

- Superminiature type, light-weight snap action switch
- PC board terminal type (0.2g .007oz)

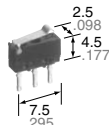

- Solder terminal type with mounting holes (0.3g .011oz)

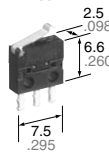

mm inch

- Mechanical life of 300,000 operations minimum
- Stainless steel plated silver or gold is used for actuating spring
- Switches can be mounted close together in any directions

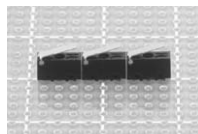
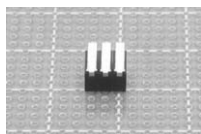

ORDERING INFORMATION

Ex. AV 4 4 0 4 61

Product Name	Terminals	Actuators	Operating force, max. (by pin plunger)	Contacts
FU	0: Solder terminal with mounting holes (1.65 mm dia. .065 inch dia.) 4: PC board straight terminal 5: PC board angle terminal 6: PC board reverse angle terminal	0: Pin plunger 2: Hinge lever 4: Simulated roller lever	4: 0.98 N {100 gf}	Nil: Silver contact 61: Gold contact

CONSTRUCTION

PC board straight terminal type

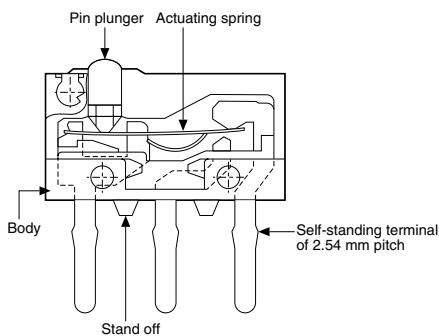

SCHEMATIC

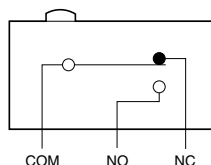

PRODUCT TYPES

Type of contacts	Actuator	Operating force, Max.	Type No.			
			PC board terminal			Solder terminal with mounting holes
			Straight terminal	Angle terminal	Reverse angle terminal	
Silver contact type	Pin plunger	0.98 N {100 gf}	AV4404	AV4504	AV4604	AV4004
	Hinge lever	0.25 N {25 gf}	AV4424	AV4524	AV4624	AV4024
	Simulated roller lever	0.29 N {30 gf}	AV4444	AV4544	AV4644	AV4044
Gold contact type	Pin plunger	0.98 N {100 gf}	AV440461	AV450461	AV460461	AV400461
	Hinge lever	0.25 N {25 gf}	AV442461	AV452461	AV462461	AV402461
	Simulated roller lever	0.29 N {30 gf}	AV444461	AV454461	AV464461	AV404461

SPECIFICATIONS

1. Contact rating

Type of contact	Resistive load ($\cos\phi \approx 1$)
Silver contact	0.5A 30V DC
Gold contact	0.1A 30V DC

2. Characteristics

Items		Characteristics	
Life	Mechanical	Min. 3×10^5 operations (at 60 cpm)	
	Electrical	Silver contact	Min. 2×10^4 operations (0.5A 30V DC; at 20 cpm)
		Gold contact	Min. 2×10^5 operations (0.1A 30V DC; at 20 cpm)
Insulation resistance		Min. 100 M Ω (250V DC by insulation resistance meter)	
Voltage withstand	Between non-continuous terminals	500V AC for 1 min.	
	Between each terminal and other exposed metal parts	500V AC for 1 min.	
	Between each terminal and ground	500V AC for 1 min.	
Vibration resistance	Pin plunger type	10 to 55 Hz at single amplitude of 0.75mm (contact opening: max. 1 msec.)	
	Lever type	10 to 55 Hz at single amplitude of 0.15mm (contact opening: max. 1 msec.)	
Shock resistance	Pin plunger type	Min. 294m/s ² {30G} (contact opening: max. 1 msec.)	
	Lever type	Min. 147m/s ² {15G} (contact opening: max. 1 msec.)	
Contact resistance (initial value)		Max. 200 m Ω (by YHP4328A)	
Allowable operation speed		0.1mm/s to 500mm/s (pin plunger type)	
Mechanical max. switching frequency		60 operations/min.	
Ambient temperature		-25 to +80°C -13 to +176°F (Not freezing below 0°C 32°F)	
Ambient humidity		Max. 85% R.H.	
Unit weight		PC board terminal type: Approx. 0.2g .007oz Solder terminal with mounting holes type: Approx. 0.3g .011oz	

DATA

Gold contact type

Range of low-level current and voltage

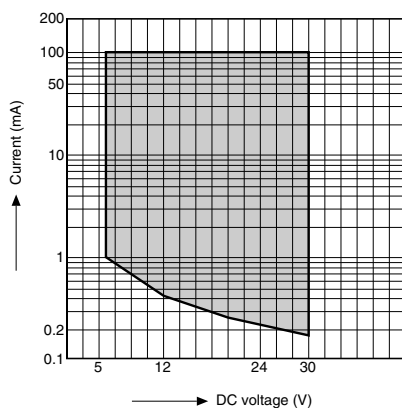

AV4

DIMENSIONS

mm inch General tolerance $\pm 0.15 \pm .006$

1. PC board terminal

Straight terminal
Pin plunger type

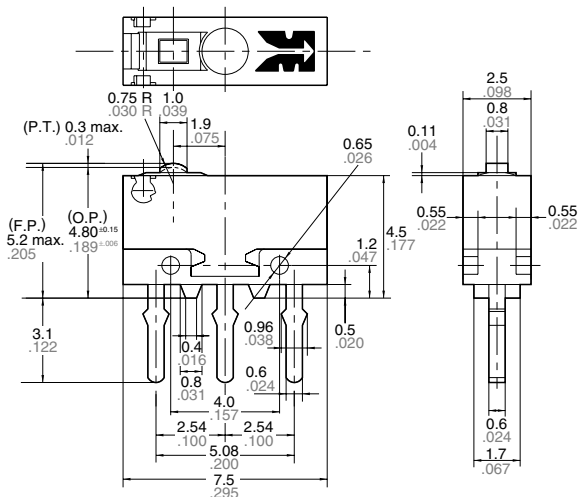

PC board pattern

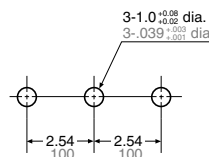

Pretravel	0.3 .012 max.
Movement Differential	0.1 .004 max.
Overtravel	0.1 .004 min.
Operating Position	4.8 \pm 0.15 .189 \pm .006
Free Position	5.2 .205 max.

Hinge lever type

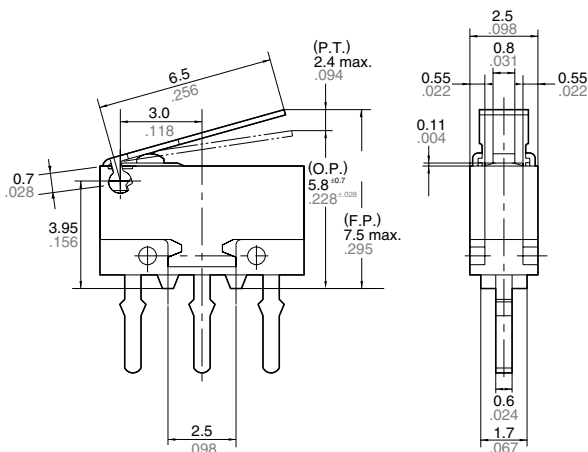

Pretravel	2.4 .094 max.
Movement Differential	0.7 .028 max.
Overtravel	0.4 .016 min.
Operating Position	5.8 \pm 0.7 .228 \pm .028
Free Position	7.5 .295 max.

Note: All other dimensions are the same as those of pin plunger type.

Simulated roller lever type

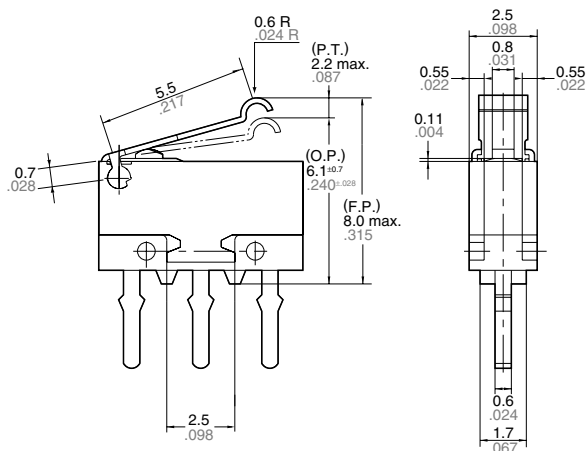

Pretravel	2.2 .087 max.
Movement Differential	0.7 .028 max.
Overtravel	0.3 .012 min.
Operating Position	6.1 \pm 0.7 .240 \pm .028
Free Position	8.0 .315 max.

Note: All other dimensions are the same as those of pin plunger type.

2. Angle terminal
Right angle terminal
Pin plunger type

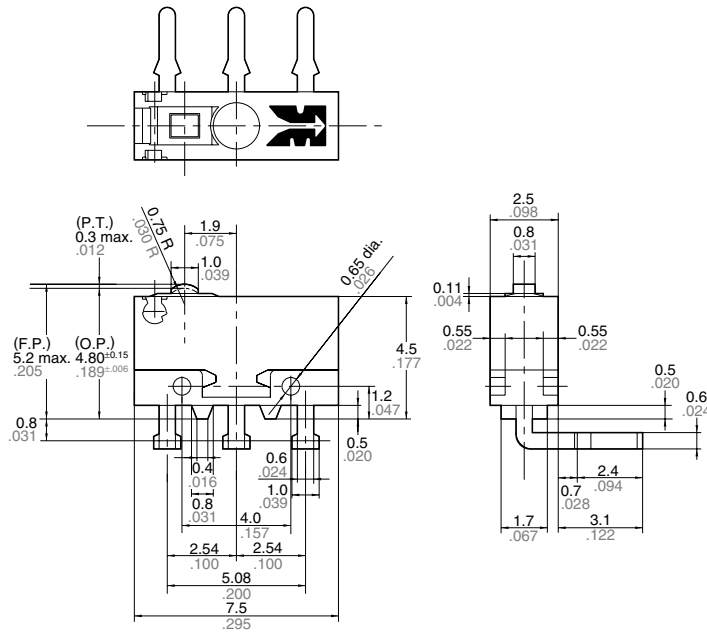
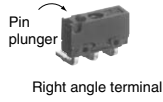

Pretravel	0.3 .012 max.
Movement Differential	0.1 .004 max.
Overtravel	0.1 .004 min.
Operating Position	4.8±0.15 .189±.006
Free Position	5.2 .205 max.

Note: All other dimensions of hinge lever type and simulated roller lever type are the same as those of straight terminal types.

Left angle terminal
Pin plunger type

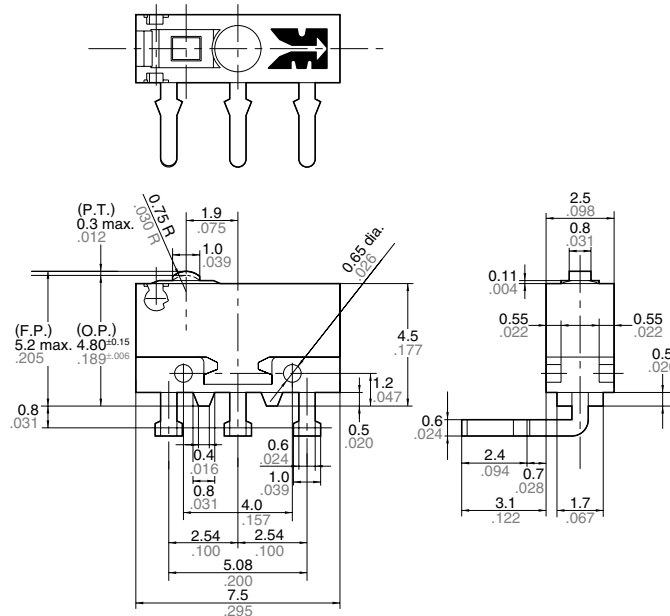
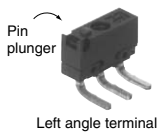

Pretravel	0.3 .012 max.
Movement Differential	0.1 .004 max.
Overtravel	0.1 .004 min.
Operating Position	4.8±0.15 .189±.006
Free Position	5.2 .205 max.

Note: All other dimensions of hinge lever type and simulated roller lever type are the same as those of straight terminal types.

3. Solder terminal with mounting holes
Pin plunger type

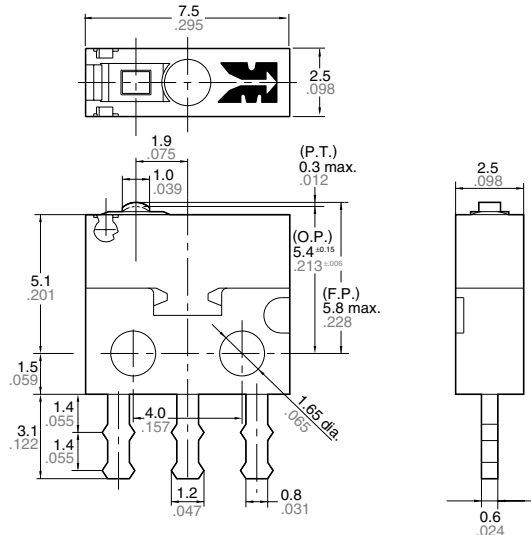

Pretravel	0.3 .012 max.
Movement Differential	0.1 .004 max.
Overtravel	0.1 .004 min.
Operating Position	5.4±0.15 .213±.006
Free Position	5.8 .228 max.

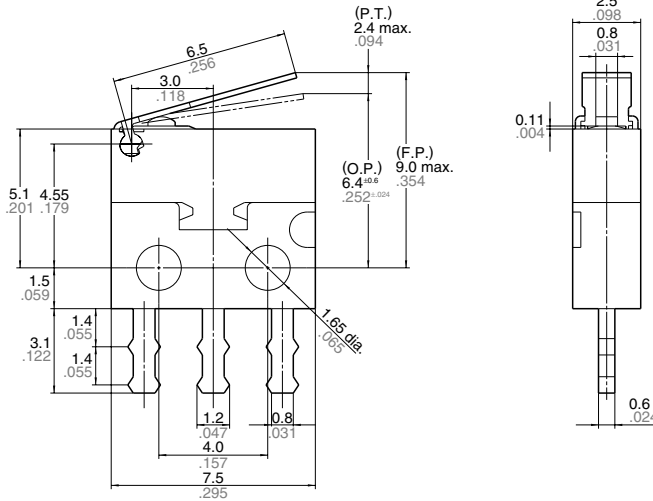

Pretravel	2.4 .094 max.
Movement Differential	0.7 .028 max.
Overtravel	0.4 .016 min.
Operating Position	6.4±0.6 .252±.024
Free Position	9.0 .354 max.

Note: All other dimensions are the same as those of pin plunger type.

Simulated roller lever type

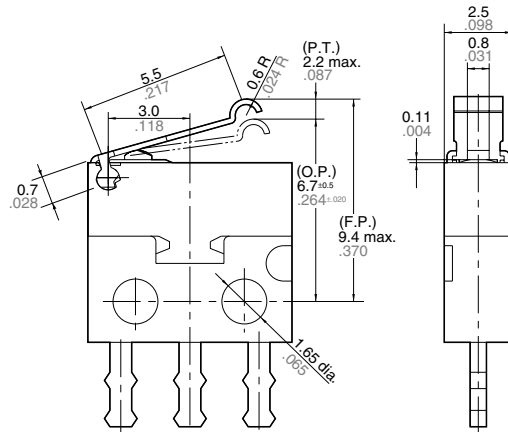

Pretravel	2.2 .087 max.
Movement Differential	0.7 .028 max.
Overtravel	0.3 .012 min.
Operating Position	6.7±0.5 .264±.020
Free Position	9.4 .370 max.

Note: All other dimensions are the same as those of pin plunger type.

NOTES

1. Mounting

- 1) After mounting and wiring, the insulation distance between ground and each terminal should be confirmed as sufficient.
- 2) When the operation object is in the free position, force should not be applied to the actuator or to the pin plunger. Also force should be applied to the pin plunger from vertical direction to the switch.
- 3) In setting the movement after operation, the over-travel should be set within the range of the specified O.T. value.
- 4) In fastening the switch body, use the M1.4 screw, with tightening torque of not more than 1 kg-cm. To prevent loosening of the screws, it is recommended that spring washers be used with the screws and adhesive be applied to lock the screws.

2. Soldering

- 1) Hand soldering should be accomplished in less than 5 seconds with an iron below 18 watts. Keep the soldering tip temperature less than 320°C 608°F. Avoid applying force to the terminals.
- 2) In the case of automatically soldering bath, soldering should be done less than 5 seconds in 260°C 500°F solder bath.
- 3) Terminal portion must not be moved within 1 minute after soldering. Also no tensile strength of lead wires should be applied to the terminals.
- 4) When using the angle terminal type, insert an insulation separator between the switch body and the printed circuit board (Insulation separator 0.2 to 0.4mm .008 to .016 inch thick) to prevent the soldering flux from flowing under the PC board.

3. Cleaning

As FU switch is not completely sealed construction, avoid cleaning.

4. Selection of switch

When specifying FU switches, allow $\pm 20\%$ to the listed operating characteristics.

5. Avoid using and keeping switches in the following conditions:

- In corrosive gases
- In a dusty environment
- Where silicon atmosphere prevails

6. When switching low-level circuits (max. 100 mA), gold contact types are recommended.

7. When using the lever type, avoid applying force from the reverse and side direction of actuating.